

300-5052

POWER CLEAN 5.0



300-5052 Power Clean 5.0, 3.6 gpm @ 2000 PSI
Power Rating: 240vAC/30A Dedicated Circuit for each unit

FEATURES:

- » Totally-Enclosed, Fan-Cooled 5HP Industrial Motor
- » 3.6 GPM, 3 Cylinder, Stainless Steel Lined, Ceramic Plunger Pump
- » SSR w/ Integrated LED for Basic System Status
- » Dual Chemical Injection System w/ Stainless Steel Injectors and Post Pump Injection
- » Anti-Backflow/Anti-Siphon Protection w/ 1" Air Gap via Water Level Float Tank
- » Low Water Shut-Off protection
- » Thermal Limit Switch for Over Temp Protection (150° Max Water Temp)
- » Includes 36" Dual Nozzle Spray Gun
- » Includes Water Filter Assembly, Replacement Filter Cartridge, and Oil
- » Unit Comes Ready to Wire. **Does Not include Power Cord.**
- » Shipping Weight: 315 lbs

(800) 548-3373

www.spraymastertech.com

A brand line of
Assembled Products Corporation

115 E Linden • Rogers, Arkansas 72756 USA | Office: (479) 636-5776 • Fax: (479) 636-3245



FRONT VIEW

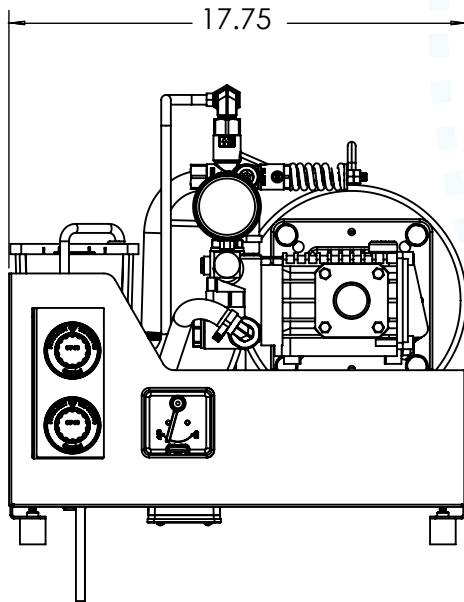

TOP VIEW

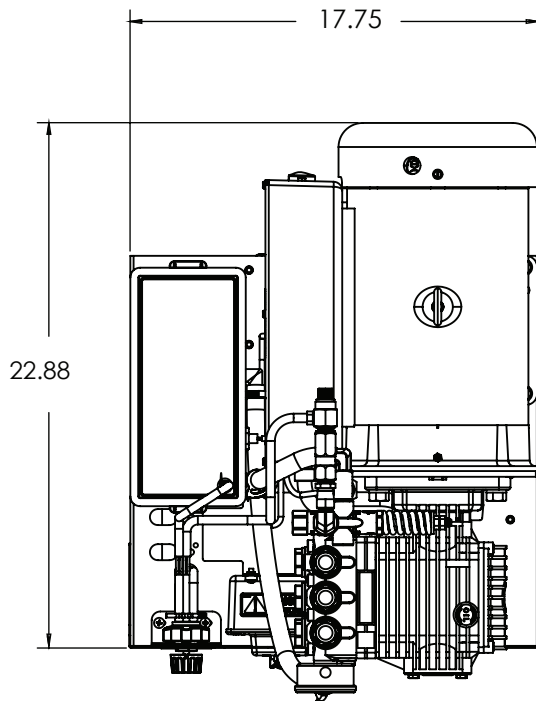

SIDE VIEW

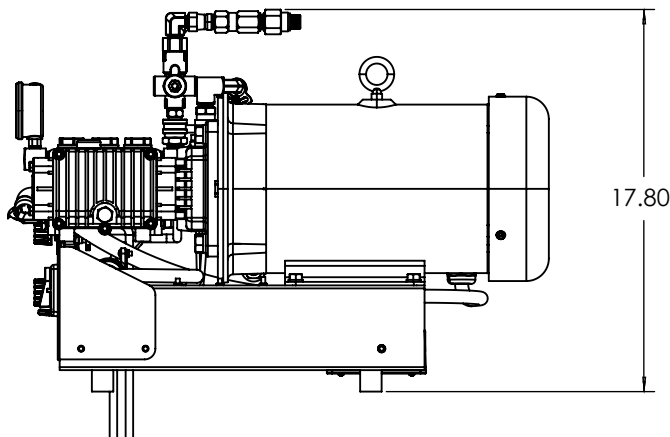

EQUIPMENT SPECS:

CLEARANCES

- » Left Side 10"
- » Right Side 10"
- » Overhead 21"
- » Above Finished Floor 36"
- » Front 16"

PLUMBING

3/4" / 2cm Hose Bib with 5 gpm / .14Lpm @ Min. 30 to 80 psi / 20.6 to 5.5 bars. If Warm Water is required, 150° F / 65.5° C Max.

ELECTRICAL

One (1) 240v 60Hz, Single Phase 30A, GFCI Protected 'Dedicated Circuit'

CHEMICAL DILUTION

Dual Chemical Metering Valves accurately adjust chemical metering to your chemical specifications.

INSTALLATION SPECS:

ELECTRICAL

One (1) 240v 60Hz, Single Phase 30A, GFCI Protected 'Dedicated Circuit'

WATER

One (1) water outlet with standard 3/4" / 1.9cm hose bib with shut-off valve. A pressure gauge in the water line can be helpful although it is not mandatory. A minimum of 5 gal / 19L per minute and a line pressure not less than 30 psi / 20.6 bars, and not more than 80psi / 5.5 bars, is required.

(Option: if warm water outlet is needed - 150° F / 65.5° C MAX)

LOCATION

Heated utility room or closet with ventilation. Minimum 24" / 60.96cm clearance above unit is required. The unit can be serviced without removing it from the wall.

GENERAL RECOMMENDATIONS

Floor drains are essential in new facilities to receive the greatest utilization and maximum efficiency of your **Spray Master** pressure washer. Materials and wall coverings which can be cleaned with pressurized water are desirable. Locate electrical outlets above washing areas.

5052, 240V, SINGLE UNIT ON WALL MOUNT BRACKETS

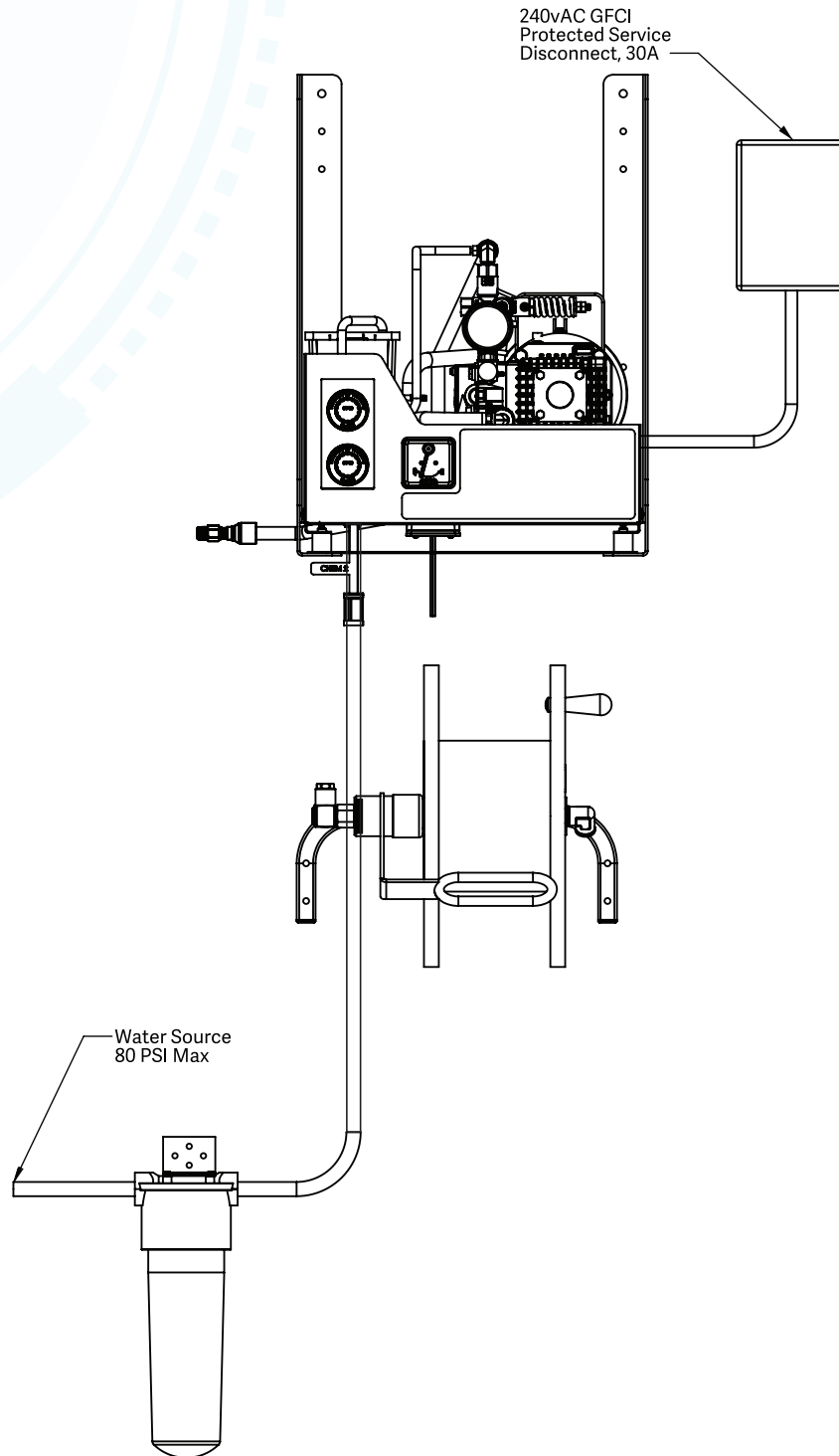

SYSTEM REQUIREMENTS:

- » One (1) 240v 60Hz, Single Phase 30A, GFCI Protected 'Dedicated Circuit'
- » 3/4" Backing required in studded walls

NOTE: Electrical, Water, and Backing are not supplied by Spray Master.

AMBIENT WATER SUPPLY

Recommended Temp: Cold water, 5 gpm @ minimum (30-80 psi) with a maximum of 80 PSI with 3/4" Hose Bib (*one for each unit*)

Maximum Temp: 150° F / 65.5 C, 5 gpm @ minimum (30-80 psi) with a maximum of 80 psi with a 3/4" Hose Bib (*one for each unit*)



www.spraymastertech.com