



## Electric Booster Heater

For use in commercial kitchens and restaurants to supply 180°F sanitizing rinse water

**The Hubbell Expeditor Series is designed to save you time and money. They are easy to install and service — no components need to be removed to replace any other components.**

- All stainless steel tank ASME Section VIII stamped construction
- Advanced electronic temperature control with digital display
- Internal electronic leak detection system
- Factory packaged resettable circuit breakers
- Pressure reducing valve with built-in bypass
- Screw plug elements with O-ring gasket
- Overall dimensions and connection locations are compatible with other popular brands
- Environmentally friendly CFC/HCFC free closed cell foam insulation minimizes tank heat loss
- Full ten (10) year (non pro-rated) tank warranty

### Applications

Restaurants, schools, hospitals, casinos, country clubs, banquet centers, correctional facilities, food preparation facilities, and much more.



13 / 16 / 116  
EXPEDITOR SERIES

### A long lasting booster heater

The Hubbell Expeditor Series J Models utilize a heavy duty ASME Section VIII designed, constructed and stamped all stainless steel tank which does not require an internal tank lining. All Hubbell Expeditor booster heaters are equipped with an electronic temperature controller with digital display to provide accurate, reliable and energy efficient operation while simplifying service work. The closed cell foam insulation improves operating efficiency and reduces the cost of operation.

Hubbell booster heaters are the right choice for your food service applications. Our boosters are designed, engineered, and manufactured for reliability and longevity coupled with unparalleled support and service.

**Get a booster heater from the booster heater experts.**

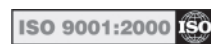

## Why Install A Hubbell Booster Water Heater?

### Improved longevity

The stainless steel tank is designed, constructed and stamped in strict conformance to ASME Section VIII.

### Lower operating costs

Environmentally friendly CFC/HCFC free closed cell foam insulation minimizes stand-by heat loss. Our high quality insulation is better at reducing heat loss than the fiberglass type insulation found in other brands.

### Reduced service and maintenance costs

- All components are removable without disturbing any other component.
- The digital display provides exact set point temperature (there is no calibration necessary), as well as visual error indication.
- The heating elements and sensing probe are straight thread screw types that utilize an O-ring to minimize leakage common with flat gaskets and NPT connections.



All sensing functions are integrated into ONE probe which can be replaced without draining the tank

Brushed stainless steel exterior increases life and looks great



Electronic control module integrates all control functions into one component

Magnetic contactor

Closed cell foam insulation lowers operating costs

Single point power connection

Leak detection system notifies the user if water is detected inside the control area

ASME stamped all stainless steel tank for extended life

Screw plug elements simplify service

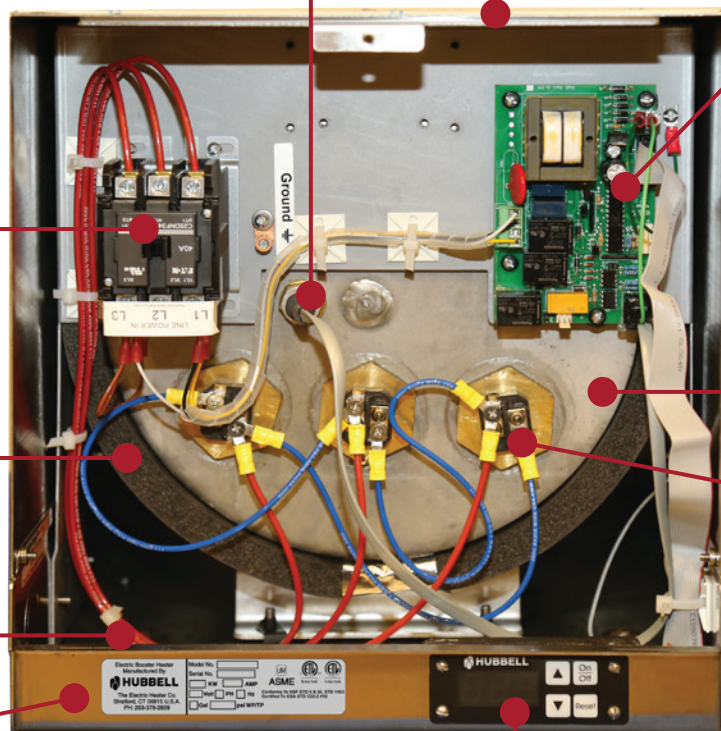

Digital display provides visual set point and fault conditions. Operator controls are easily accessible including ON/OFF, reset, and temperature adjustment

### 3 Gallon KW Selection Chart

KW	Full Model Number Listed by Voltage and Phase								Amperage Draw by Voltage and Phase						
	1 Phase Voltages				3 Phase Voltages				1 Phase Voltages			3 Phase Voltages			
	120	208	240	480	208	240	480	600	120	208	240	208	240	480	600
2.9	J32.9A	—	—	—	—	—	—	—	24	—	—	—	—	—	—
5.7	J35.7A	—	—	—	—	—	—	—	38	—	—	—	—	—	—
9.9	—	J39.9RS	—	—	J39.9R	—	—	—	—	48	—	28	—	—	—
10.4	—	J310.4RS	—	—	J310.4R	—	—	—	—	50	—	29	—	—	—
11.4	—	—	J311.4S	—	—	J311.4T	J311.4T4	J311.4T6	—	—	48	—	27	14	11

### 6 Gallon KW Selection Chart

KW	Full Model Number Listed by Voltage and Phase								Amperage Draw by Voltage and Phase						
	1 Phase Voltages				3 Phase Voltages				1 Phase Voltages			3 Phase Voltages			
	120	208	240	480	208	240	480	600	120	208	240	208	240	480	600
1	J61A	—	—	—	—	—	—	—	8	—	—	—	—	—	—
1.5	J61.5A	—	—	—	—	—	—	—	13	—	—	—	—	—	—
2	J62A	—	—	—	—	—	—	—	17	—	—	—	—	—	—
3	J63A	—	—	—	—	—	—	—	25	—	—	—	—	—	—
4	—	J64RS	J64S	J64T4S	—	—	—	—	—	19	17	—	—	—	—
5	—	J65RS	J65S	J65T4S	—	—	—	—	—	24	21	—	—	—	—
6	—	J66RS	J66S	—	J66R	J66T	J66T4	J66T6	—	29	25	17	14	7	6
7	—	J67RS	J67S	—	J67R	J67T	J67T4	J67T6	—	34	29	19	17	8	7
9	—	J69RS	J69S	—	J69R	J69T	J69T4	J69T6	—	43	38	25	22	11	9
10.5	—	J610RS	J610S	—	J610R	J610T	J610T4	J610T6	—	50	44	29	25	13	10
12	—	J612RS	J612S	—	J612R	J612T	J612T4	J612T6	—	58	50	33	29	14	12
13.5	—	J613RS	J613S	—	J613R	J613T	J613T4	J613T6	—	65	56	38	33	16	13
15	—	J615RS	J615S	—	J615R	J615T	J615T4	J615T6	—	72	63	42	36	18	14
18	—	J618RS	J618S	—	J618R	J618T	J618T4	J618T6	—	87	75	50	43	22	17
24	—	J624RS	J624S	—	J624R	J624T	J624T4	J624T6	—	115	100	67	58	29	23
27	—	J627RS	J627S	—	J627R	J627T	J627T4	J627T6	—	130	113	75	65	33	26
30	—	J630RS	J630S	—	J630R	J630T	J630T4	J630T6	—	144	125	83	72	36	29
36	—	J636RS	J636S	—	J636R	J636T	J636T4	J636T6	—	173	150	100	87	43	35
39	—	J639RS	J639S	—	J639R	J639T	J639T4	J639T6	—	188	163	108	94	47	38
40.5	—	J640RS	J640S	—	J640R	J640T	J640T4	J640T6	—	195	169	113	98	49	39
45	—	—	J645S	—	J645R	J645T	J645T4	J645T6	—	—	188	125	108	54	43
54	—	—	—	—	J654R	J654T	J654T4	J654T6	—	—	—	150	130	65	52
58.5	—	—	—	—	J658R	J658T	J658T4	J658T6	—	—	—	163	141	70	56

**Notes:**

1. The 6, 7, and 9KW models in 208 and 240 volt can be field converted from either 1 phase to 3 phase or from 3 phase to 1 phase.
2. All 3 phase units are factory wired as a balanced 3 phase unit.
3. J Models are also available in 380, 415, 440 and 575 volt. Please consult factory for exact KW selection in these voltages.

**16 Gallon ( with 3/4" inlet/outlet) KW Selection Chart**

KW	Full Model Number Listed by Voltage and Phase								Amperage Draw by Voltage and Phase							
	1 Phase Voltages				3 Phase Voltages				1 Phase Voltages				3 Phase Voltages			
	120	208	240	480	208	240	480	600	120	208	240	208	240	480	600	
1	J161A	—	—	—	—	—	—	—	8	—	—	—	—	—	—	
1.5	J161.5A	—	—	—	—	—	—	—	13	—	—	—	—	—	—	
2	J162A	—	—	—	—	—	—	—	17	—	—	—	—	—	—	
3	J163A	—	—	—	—	—	—	—	25	—	—	—	—	—	—	
4	—	J164RS	J164S	J164T4S	—	—	—	—	—	19	17	—	—	—	—	
5	—	J165RS	J165S	J165T4S	—	—	—	—	—	24	21	—	—	—	—	
6	—	J166RS	J166S	—	J166R	J166T	J166T4	J166T6	—	29	25	17	14	7	6	
7	—	J167RS	J167S	—	J167R	J167T	J167T4	J167T6	—	34	29	19	17	8	7	
9	—	J169RS	J169S	—	J169R	J169T	J169T4	J169T6	—	43	38	25	22	11	9	
10.5	—	J1610RS	J1610S	—	J1610R	J1610T	J1610T4	J1610T6	—	50	44	29	25	13	10	
12	—	J1612RS	J1612S	—	J1612R	J1612T	J1612T4	J1612T6	—	58	50	33	29	14	12	
13.5	—	J1613RS	J1613S	—	J1613R	J1613T	J1613T4	J1613T6	—	65	56	38	33	16	13	
15	—	J1615RS	J1615S	—	J1615R	J1615T	J1615T4	J1615T6	—	72	63	42	36	18	14	
18	—	J1618RS	J1618S	—	J1618R	J1618T	J1618T4	J1618T6	—	87	75	50	43	22	17	
24	—	J1624RS	J1624S	—	J1624R	J1624T	J1624T4	J1624T6	—	115	100	67	58	29	23	
27	—	J1627RS	J1627S	—	J1627R	J1627T	J1627T4	J1627T6	—	130	113	75	65	33	26	
30	—	J1630RS	J1630S	—	J1630R	J1630T	J1630T4	J1630T6	—	144	125	83	72	36	29	
36	—	J1636RS	J1636S	—	J1636R	J1636T	J1636T4	J1636T6	—	173	150	100	87	43	35	
39	—	J1639RS	J1639S	—	J1639R	J1639T	J1639T4	J1639T6	—	188	163	108	94	47	38	
40.5	—	J1640RS	J1640S	—	J1640R	J1640T	J1640T4	J1640T6	—	195	169	113	98	49	39	
45	—	—	J1645S	—	J1645R	J1645T	J1645T4	J1645T6	—	—	188	125	108	54	43	
54	—	—	—	—	J1654R	J1654T	J1654T4	J1654T6	—	—	—	150	130	65	52	
58.5	—	—	—	—	J1658R	J1658T	J1658T4	J1658T6	—	—	—	163	141	70	56	

**16 Gallon ( with 1-1/2" inlet/outlet) KW Selection Chart**

KW	Full Model Number Listed by Voltage and Phase								Amperage Draw by Voltage and Phase							
	1 Phase Voltages				3 Phase Voltages				1 Phase Voltages				3 Phase Voltages			
	120	208	240	480	208	240	480	600	120	208	240	208	240	480	600	
64	—	—	—	—	J1664R	—	—	—	—	—	—	178	—	—	—	
68	—	—	—	—	—	J1668T	J1668T4	J1668T6	—	—	—	—	164	82	66	
81	—	—	—	—	J1681R	J1681T	J1681T4	—	—	—	—	225	195	98	—	
86	—	—	—	—	J1686R	—	—	J1686T6	—	—	—	239	—	—	83	
88	—	—	—	—	—	J1688T	J1688T4	—	—	—	—	—	212	106	—	

## Booster Sizing Formula

**REQUIRED VARIABLES:** **A.** Water usage in GPH \_\_\_\_\_ **C.** Desired water temp in °F \_\_\_\_\_  
**B.** Supply water temp in °F \_\_\_\_\_ **D.** Calculate the ΔT (temp rise) by subtracting C – B in °F \_\_\_\_\_

**FORMULA TO DETERMINE KW:** \_\_\_\_\_ GPH x \_\_\_\_\_ °F ΔT x 0.00244 = \_\_\_\_\_ KW

### Recovery Ratings 1–58.5 KW

KW Rating	Recovery Rate in GPH at °F Temperature Rise (ΔT)							
	20°F ΔT	30°F ΔT	40°F ΔT	60°F ΔT	70°F ΔT	80°F ΔT	110°F ΔT	140°F ΔT
1	20	14	10	7	6	5	4	3
1.5	31	20	15	10	9	8	6	4
2	41	27	20	14	12	10	7	6
3	61	41	31	20	18	15	11	9
4	82	55	41	27	23	20	15	12
5	102	68	51	34	29	26	19	15
6	123	82	61	41	35	31	22	18
7	143	96	72	48	41	36	26	20
9	184	123	92	61	53	46	33	26
10.5	215	143	107	72	61	54	39	31
12	246	164	123	82	70	61	45	35
13.5	276	184	138	92	79	69	50	39
15	307	205	154	102	88	77	56	44
18	368	246	184	123	105	92	67	53
24	491	328	246	164	140	123	89	70
27	553	368	276	184	158	138	100	79
30	614	409	307	205	175	154	112	88
36	737	491	368	246	211	184	134	105
39	798	532	399	266	228	200	145	114
40.5	829	553	415	276	237	207	151	118
45	921	614	461	307	263	230	167	132
54	1105	737	553	368	316	276	201	158
58.5	1198	798	599	399	342	299	218	171

## Recovery Ratings 64–88 KW

KW Rating	Recovery Rate in GPH at °F Temperature Rise ( $\Delta T$ )							
	20°F $\Delta T$	30°F $\Delta T$	40°F $\Delta T$	60°F $\Delta T$	70°F $\Delta T$	80°F $\Delta T$	110°F $\Delta T$	140°F $\Delta T$
64	1310	873	655	437	374	328	238	187
68	1392	928	696	464	398	348	253	199
81	1658	1105	829	553	474	415	301	237
86	1761	1174	880	587	503	440	320	252
88	1802	1201	901	601	515	450	328	257

## Model J3 Dimensions



Shipping Weight: 46 lbs  
Note: Shown with optional legs

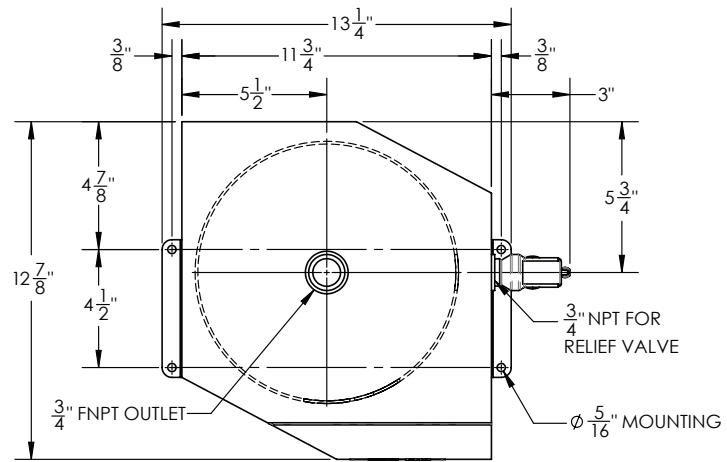

TOP VIEW

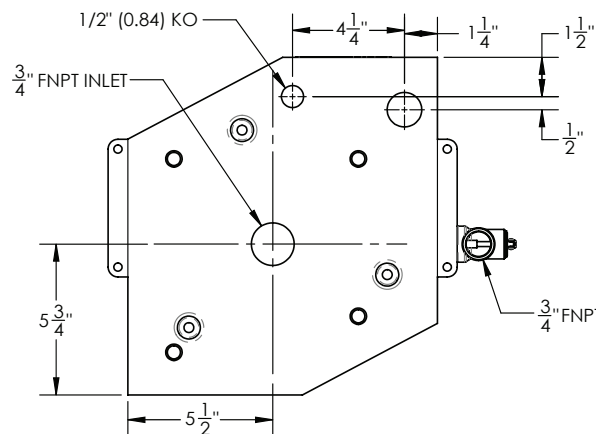
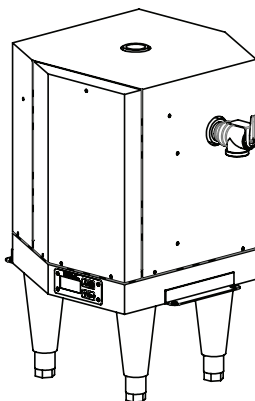

BOTTOM VIEW

### Model J6 Dimensions (18KW and under)



Shipping Weight: 95 lbs

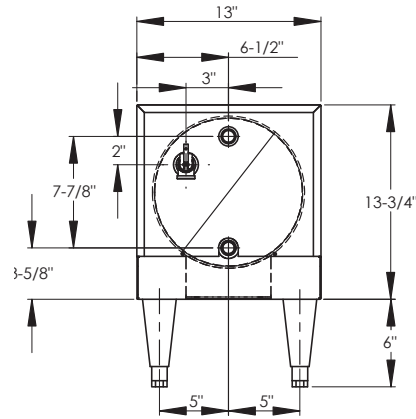

BACK VIEW

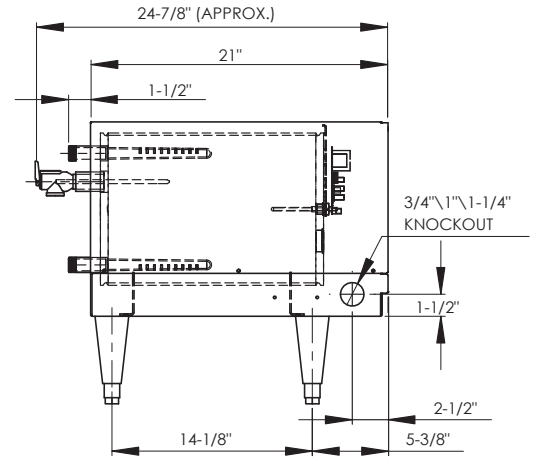

LEFT SIDE VIEW

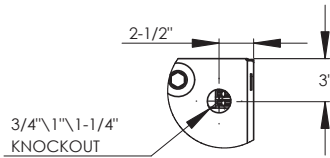

BOTTOM VIEW

### Model J6 Dimensions (24KW and over)



Shipping Weight: 110 lbs

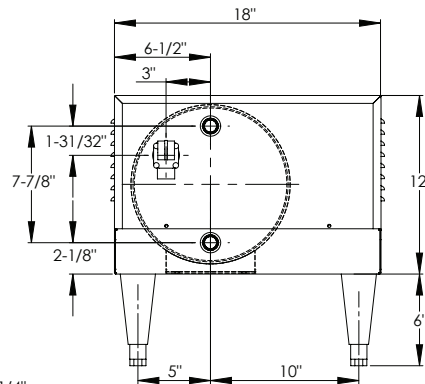

REAR VIEW

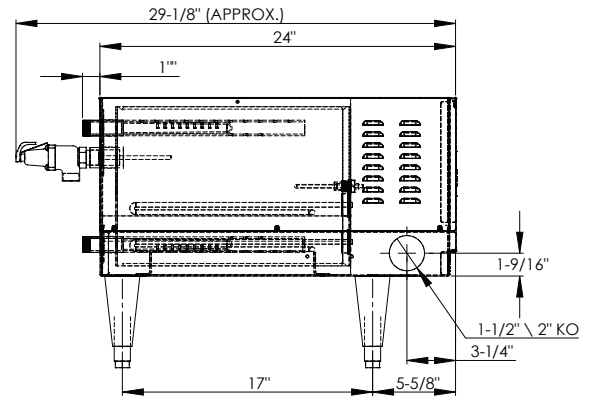

LEFT SIDE VIEW

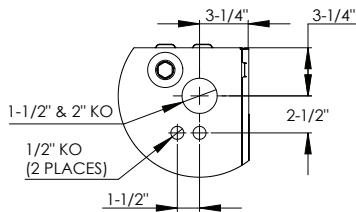

BOTTOM VIEW

## Model J16 Sample Dimensions



**Note:**

Inlet/outlet size for J16 1-58.5 KW is 3/4"

Inlet/outlet size for J16 64-88 KW is 1-1/2"

Shipping Weight: 160 lbs, for higher KW (64-88) 195 lbs

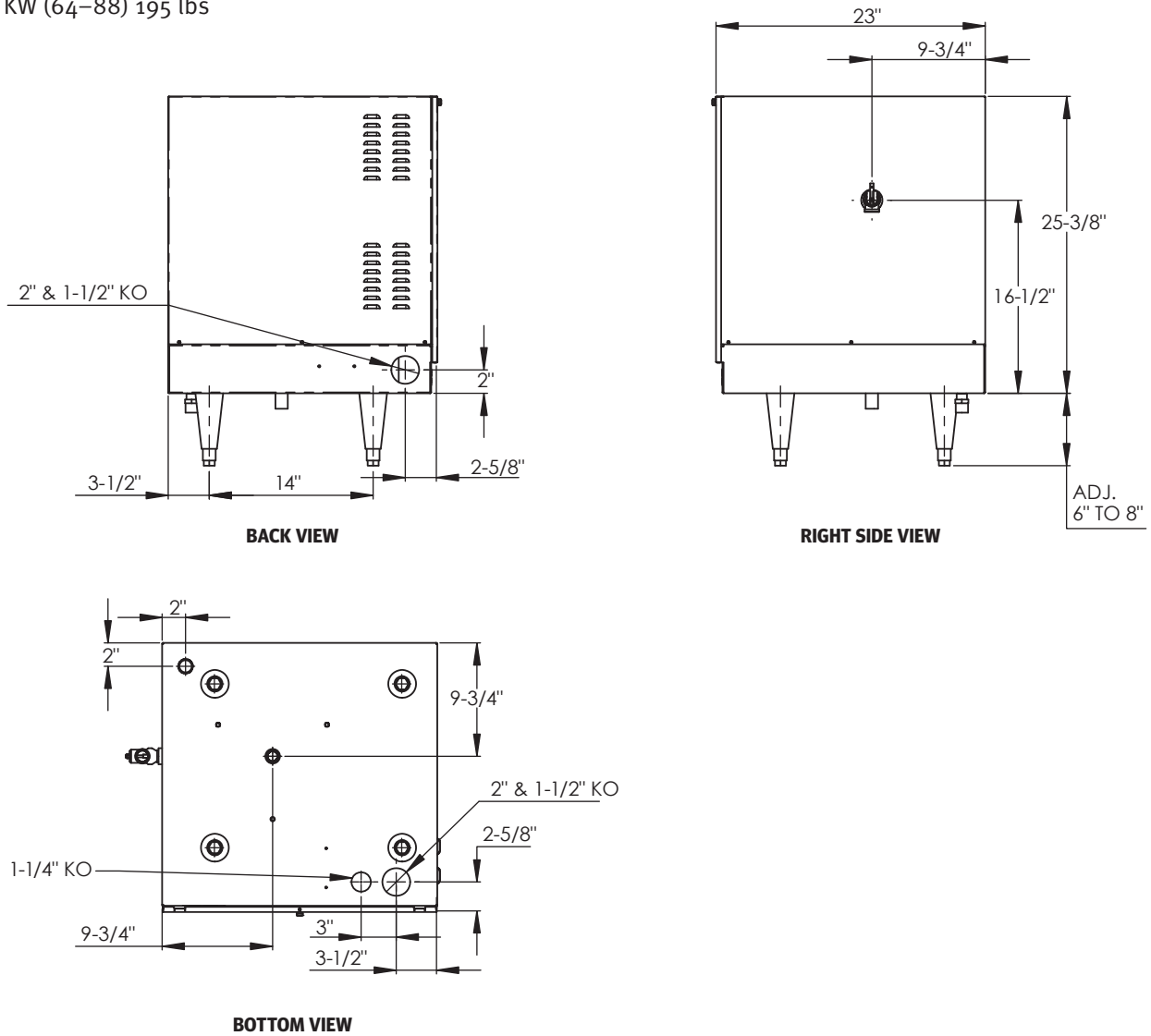



## Typical Installation Diagrams

### Typical J3 Plumbing Connections

(Front View, shown with optional legs)

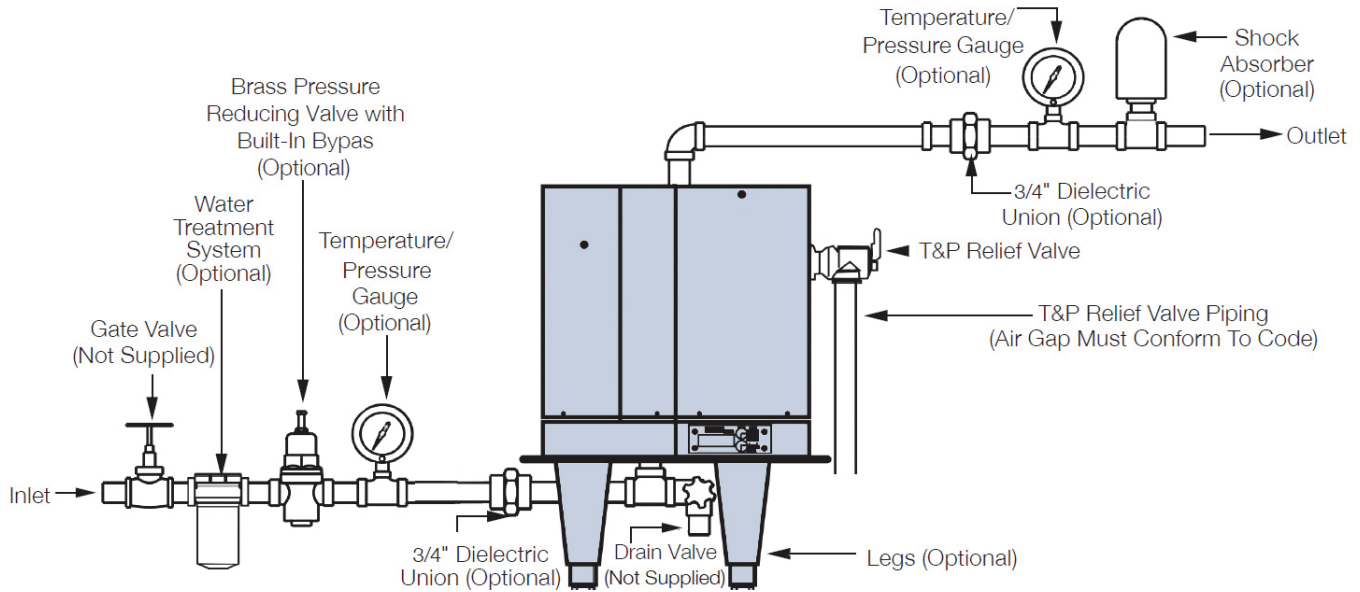

### Typical J6 Plumbing Connections

(Rear View)

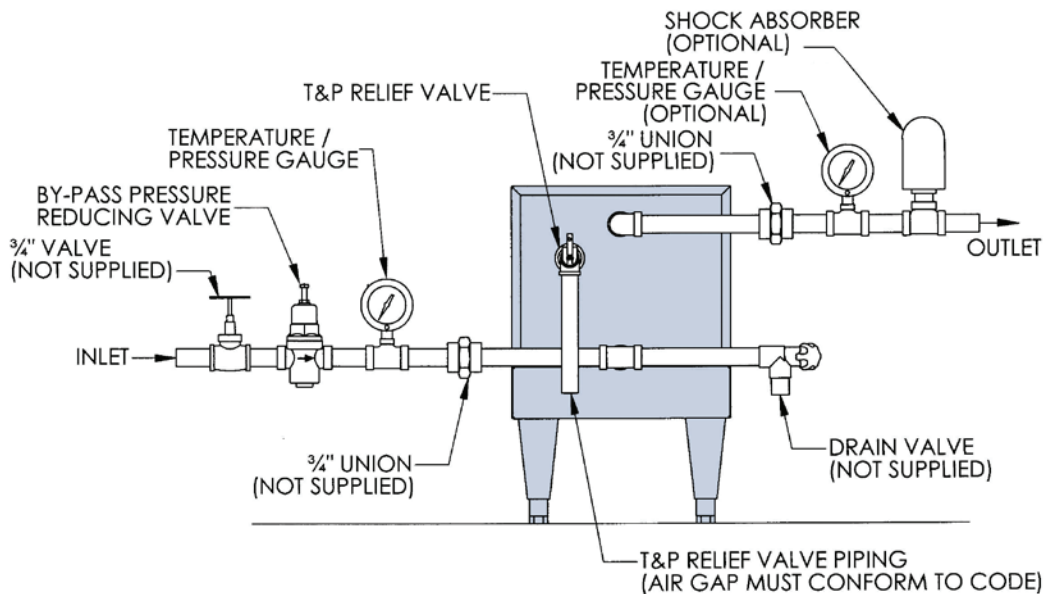

## Typical J16 Plumbing Connections

(Front View)

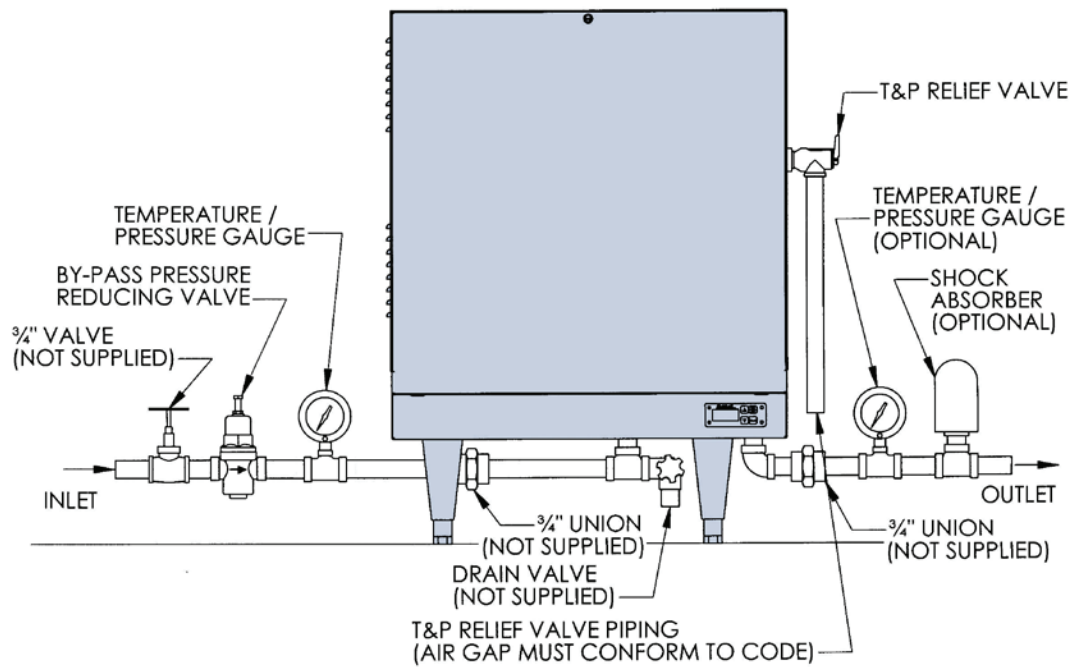

### Plumbing Notes:

1. Dielectric unions are recommended to be installed in the inlet and outlet piping to prevent electrolysis.
2. No check valve may be installed in the supply line to the booster.
3. All shut off valves must be gate or ball valves — not globe valves.
4. The pressure reducing valve with built-in bypass is adjustable from 25 – 75 psi.
5. To minimize heat loss and maximize efficiency, hot water piping should be insulated.



## Standard Features

- T&P Relief Valve
- Pressure reducing valve with built-in bypass
- Set of NSF approved plastic legs
- Combination temperature and pressure gauge
- Resettable circuit breakers (on units over 120 amps)

## Optional Equipment

**Note:** *Optional equipment must be called out in the written specifications, use the codes below.*

### Controller

- C51 Remote Control Panel:** This device allows you to install the booster in one location and have complete control of it (on/off, temperature adjustment, reset, and temperature indication) from another location (200 feet maximum). Remote control panel is 5" x 2" x 3" and NEMA 4 rated.
- C53 Low Temperature Interlock:** This device is built into the booster and monitors water temperature and will trip an SPDT relay when water temperature drops below a set point (150 - 180°F) thereby preventing final rinse from activating.
- C54 Remote Alarm Adapter:** This device installs into the Hubbell controller and provides remote alarm capability to indicate a reset fault condition. Common/N.O./N.C. rated 220 VDC, 250 VAC, 2 amp max.

**C58 24 Volt Heater Interlock Adapter:** An optional plug adapter that interlocks the heater via a 24-Volt signal through the J1 connector on the control board (standard on the J3).

### General

**G49 Tamper Resistant Package:** For prison and other secure facilities a tamper resistant package is available with all hardware tamper resistant type. Includes standard plastic legs unless otherwise specified.

**Note Alternative Voltages:** Hubbell booster heaters are available in alternate voltages including 380, 415, 440, and 575 volt. Please contact factory for KW selection.

## Available Accessories

**Slide Brackets:** Available for the J6 model only, these brackets allow for mounting the booster heater under a counter. See slide bracket diagram below for details.

Part# SLIDE BRACKETS

**Shock Absorber:** Reduce the harmful pressures resulting from quick closing dishwasher solenoid valves by installing a shock absorber between the booster and the dishwasher.

Part# SHOCK ABSORBER

**Protective Cover:** Keep your booster free from dirt, debris, chemicals, and excessive water with this removable form-fitted protective cover. Velcro fasteners make it easily installed and simple to remove when service is required. Clear window allows visibility of Hubbell booster digital display.

J6, 3 Element plastic protective shroud (1 to 18 kW)

Part# J6-3 SHROUD.

J6, 6 Element plastic protective shroud (24 to 58.5 kW)

Part# J6-6 SHROUD.

J16 Element plastic protective shroud

Part# J16 SHROUD

**Alternate Legs:** with flanged base for floor mounting.

Nickel plated legs (Price each, 4 Req'd.)

Part# AE61-4002-C

Stainless steel adjustable legs (Price each, 4 Req'd.)

Part# A50-5048-C

Floor mount legs S/S (Price each, 4 Req'd.)

Part# A50-9939-C

**Water Treatment System:** Provide superior mineral scale prevention and corrosion control by feeding a special blend of scale control compounds into the hot water stream before the booster. The in-line system includes a clear cartridge housing to allow an operator to view the cartridge and determine when it needs replacement without the need to open the system.

Part# HBW-CLEAR

**Bronze Pressure Reducing Valve:** with built-in bypass.

Part# N45BU

**Dielectric Union, 3/4":**

Part# DIELECTRIC UNION



## Complete Inventory Ready to Ship

Hubbell Expeditor booster heaters are ready to ship same day when an order is received by the factory by 12:00pm EST.

800.647.3165  
info@boosterheaters.com  
boosterheaters.com

45 Seymour Street, P.O. Box 288, Stratford, CT 06615



H1013-6-22-B