

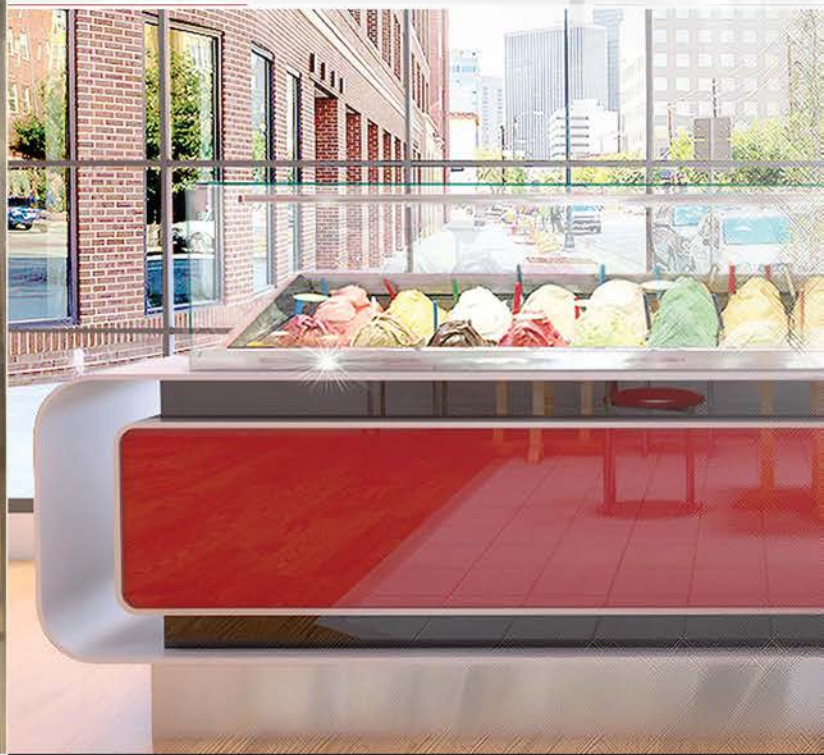

INSPIRATIONS



We see your vision , which inspires us to execute incredibly high end designs that are modularized in builds to intelligently stay within a value engineered platform!





FROM CONCEPTS ... TO REALITY

RPI

Specialties At Your Service

CAFE RPI

SWITCH

DOE 2017 COMPLIANT



Monaco M3 SERIES

flexeserve Zone®

The RPI & Nuttall flexeserve Zone® is transforming the hot food-to-go display market and changing customer expectations for the better. The multi-award-winning, heated display unit offers a range of hot self-serve food-to-go merchandising solutions in one cabinet. With 48% of food-to-go shoppers making unplanned purchases, the flexeserve Zone® is the perfect solution! The open grab & go design facilitates impulse purchases for your enticing hot food-to-go products.

The pioneering flexeserve Zone® allows operators to tailor their hot food offer according to consumer demand, reducing product waste, with the ability to turn zones off during off-peak hours or utilize the cabinet's greater merchandising capacity. flexeserve Zone® keeps your hot food tasting and looking its best for longer!



Available in 2, 3, & 4 tier formats!



Minimizes waste due to extended display times!



Increases food sales due to maximized product quality and shelf life!



Reduces energy use due to flexible zone efficiencies!



How does it work?

- Patented air handling system enables stable constant air temperature throughout the Zone.
- The high velocity air curtain ensures that the heated air is maintained at the correct temperature and protects each Zone from the exterior environment.
- Each Zone is thermally independent , enabling isolation allowing Zones switched on & off to suit trading patterns.

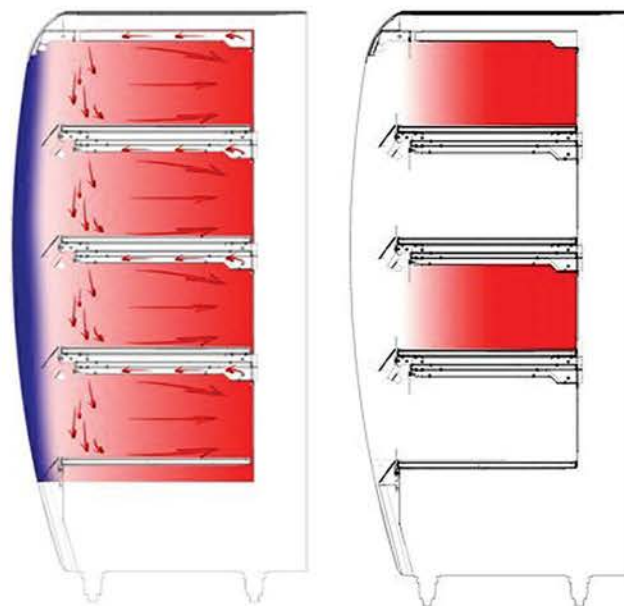

Nuttall Flexeserve Zone®	Resulting in ...
Controlled Environment	High product quality and stable temperature
Tight Air Curtain	Energy saving
Independent heated Zones	Greater economy of use
Energy efficient Controls	Variable savings per year
Flat shelf display	Safely display liquid products
Greater area of merchandising capacity	28 % increase in merchandising capacity *

Custom Printed graphics

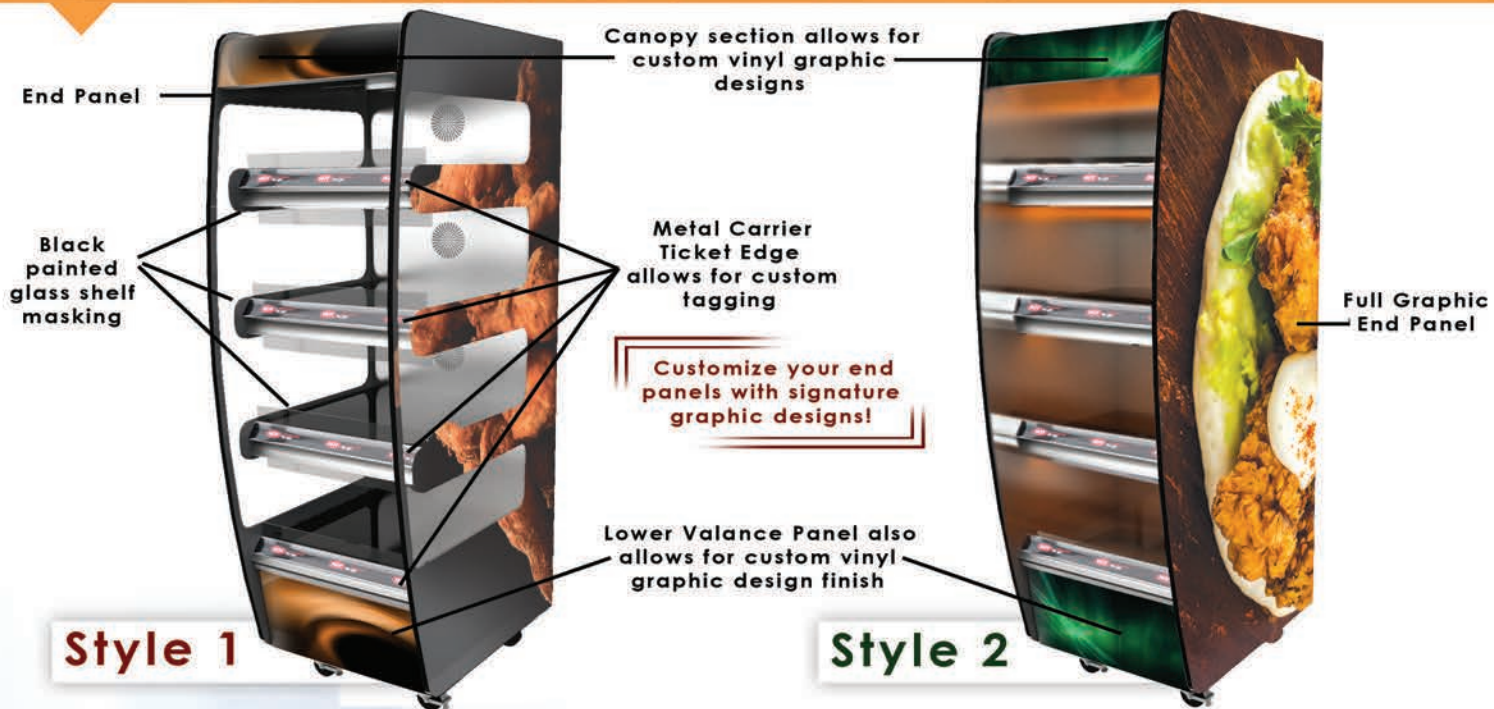



EXTENDED STYLING!
OLYMPUS MATCHING SERIES



OLYMPUS II STYLE



OLYMPUS III STYLE



A full unique line of gelato, pastry, chocolate, deli and prepared food display merchandisers!



A BRILLIANT SOLUTION



Featuring sleek glass with LED lights, continual line-up construction gives your Milan series an "endless" appearance!



IMAGINE

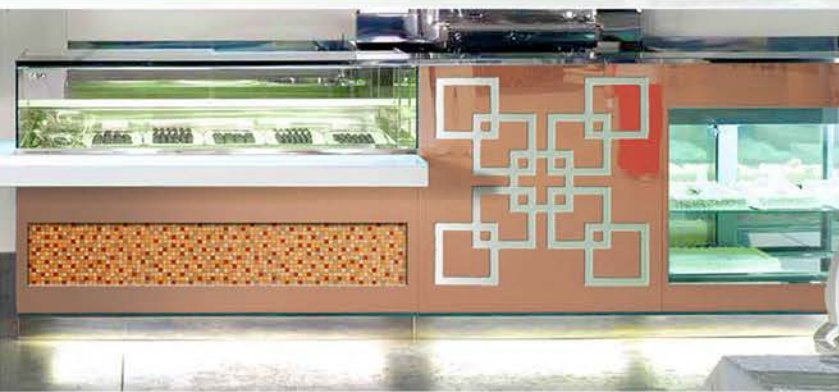

GELATO





W
M
I
L
A
N
B
A
K
E
R
Y



BAKERY

AMBIENT

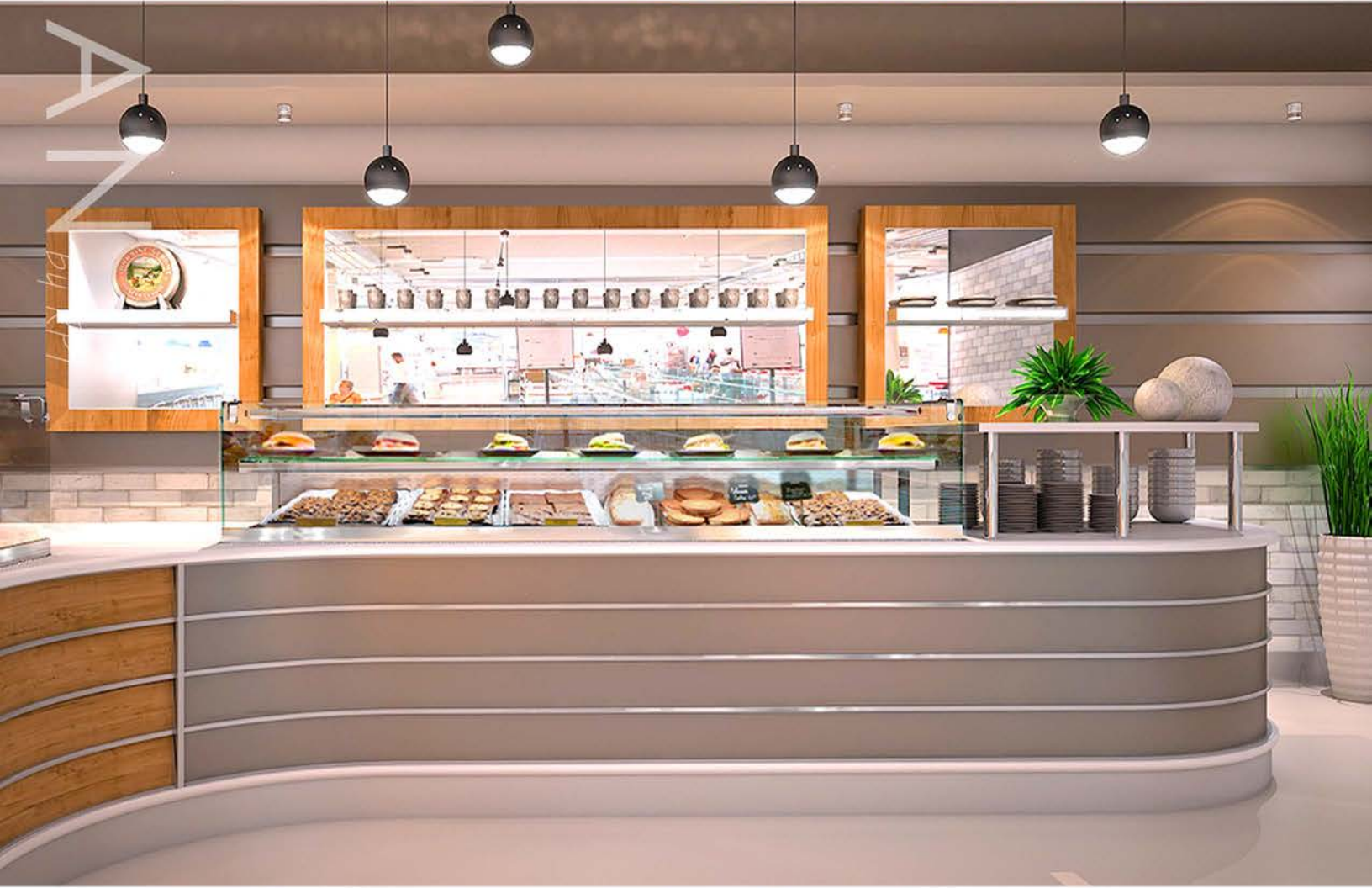



PREPARED FOODS



FLEX SERIES



The **ultimate design statement** by offering a clip-on front and side panel system, giving that added sizzle to your display cases, without adding the additional costs of including a fabricated counter or die wall!

HOW FLEX SERIES WORKS

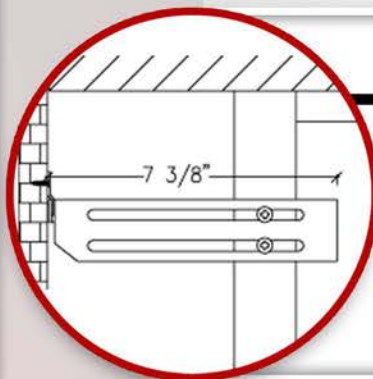
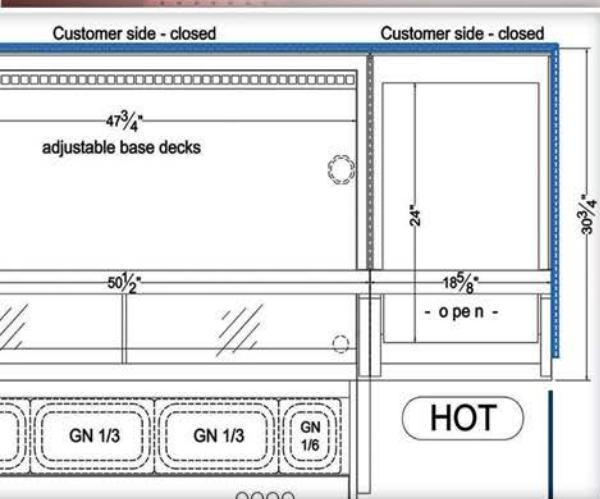
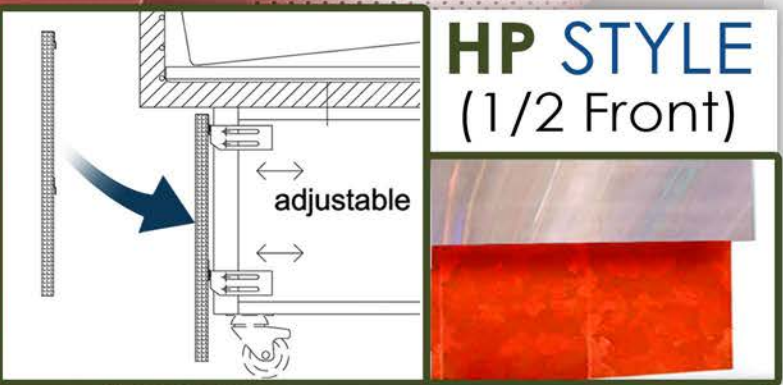
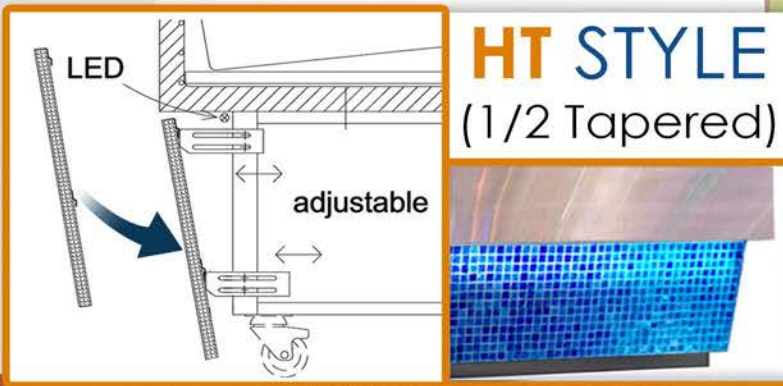
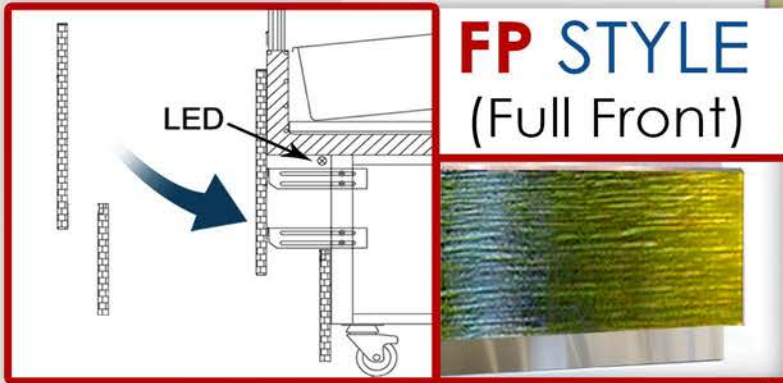

SPECIALIZED "Z-CLIPS"

Attach to the units framing, fastening your choice of paneling directly to the unit!

FRONT & SIDE CLIPS ONLY

RPI ADVANTAGE



VALUE ENGINEERED PACKAGE!

When designing your counters, in lieu of special cutting of tops and fabricating a die wall or custom cabinetry, simply leave an opening in your counter, slide in a Vienna case and apply the economical matching **FLEX PANEL!**

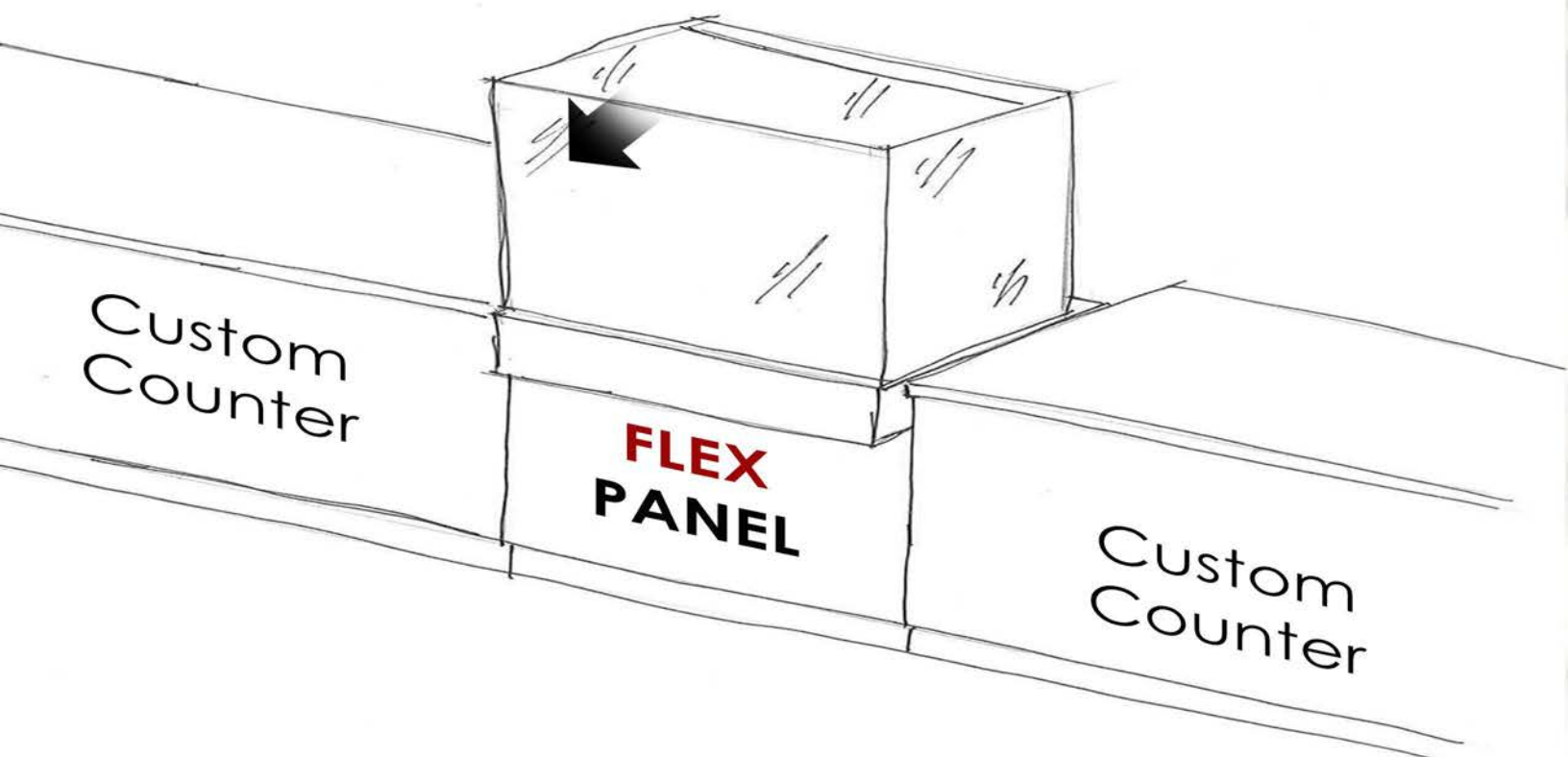

Vienna series

GRAB N GO



We added more options to our most popular Vienna grab and go units! Now available in black matte Powder Coat exterior with a finished compressor housing displaying the unit as though it was floating within the counter design!



INTRODUCING Flantastic



The Flantastic line is designed to maximize product freshness! Unit offers a uniquely designed coil with variable speed fans, which enables you to achieve very high natural humidity levels for preservation of product. This in-turn provides longer product shelf life!

Vienna PRO Series



The Vienna PRO Series offers modular formats in refrigerated, non-refrigerated and hot display in multiple arrays of configurations that can be tied together, offering a "continuous display case" look with customized appeal! Units available in exterior #4 satin stainless, #8 mirrored polished, black powder coat, or your choice of R.A.L color finish options!

RAL 9016 White	RAL 7047 Light Grey	RAL 1018 Yellow	RAL 2010 Orange	RAL 3000 Red	RAL 3004 Burgundy	RAL 5002 Dark Blue	RAL 0001500 Black	RAL 0003000 Carbon	RAL 0004000 Anthracite
RAL 0909040 Yellow	RAL 0958010 Cream	RAL 0959010 Light Yellow	RAL 1007005 Cement Grey	RAL 1009005 Ultra White	RAL 1308030 Light Green	RAL 1402020 Moss Green	RAL 1407020 Candy Green	RAL 1906025 Turquoise	RAL 2008020 Callipo



All of this at a tremendous **value-engineered price!**





HOT/COLD COMBO DISPLAY

The Hot/Cold Combo offers versatility with 4 functions in a small footprint. Angled presentation is offered for heated and refrigerated product with top isolated assisted service!

Continuous LED lighting for natural colour rendition

Long-wave, infrared warming bridge

High transparency for a perfect view of the food on display



Easy Change: liftable glass front for self- or assisted service

Main hotplate



SPECIAL FEATURES

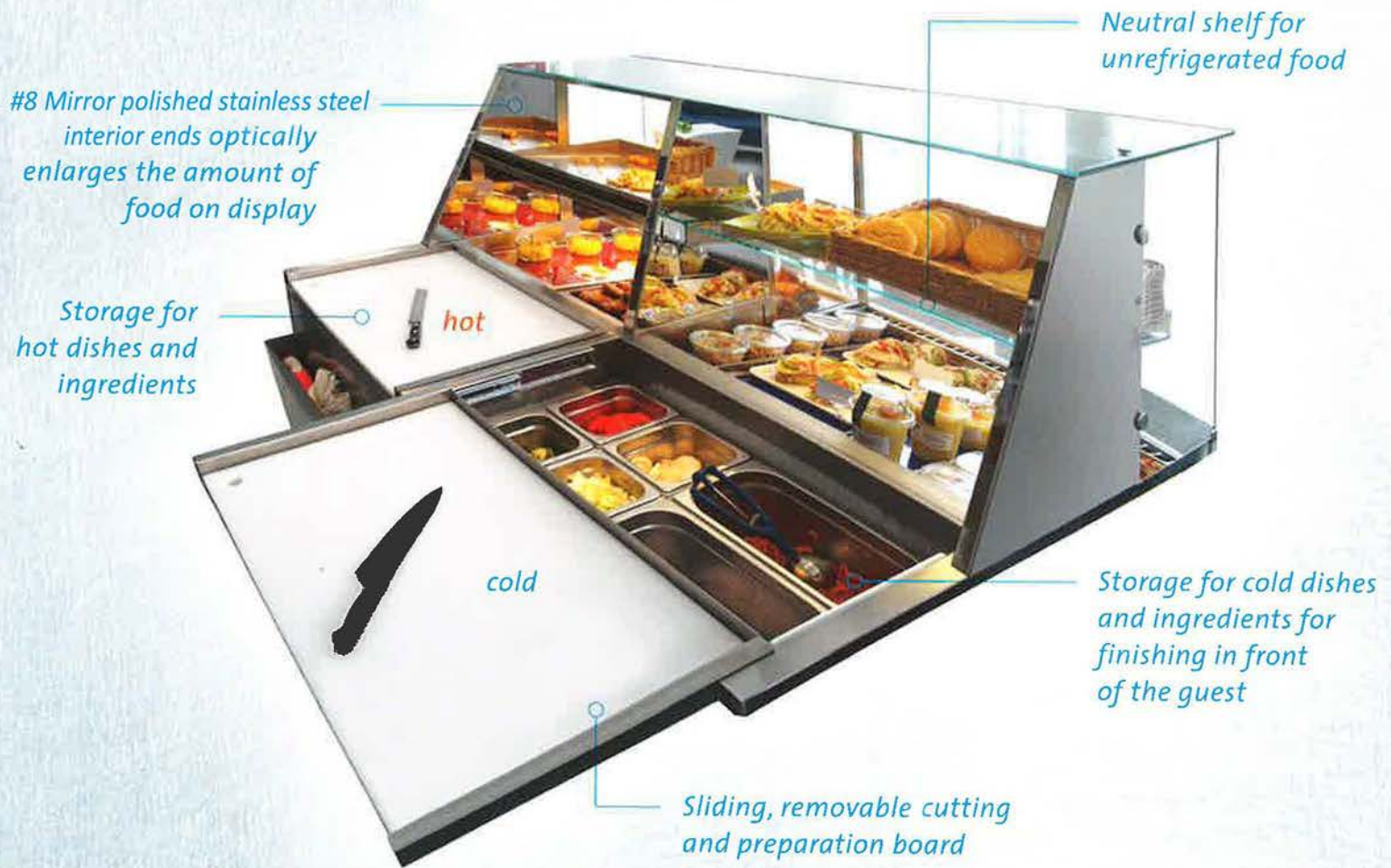

An all-day concept – simple, fast, flexible

Constantly having everything ready and close at hand represents an important precondition for efficient preparation in front of the guest. Especially when the display is to be changed frequently between breakfast and dinner. However, the case's storage system ensures that none of these issues is a problem.

Vienna Snackee



The Vienna Snackee Series Offers flexibility within a small foot print. Designed as above counter top units, with front flip-up access doors, these unique displays are available in **cool**, **heated**, and **ambient** applications, and are the perfect display case choice for impulse merchandising!



SHOWN AT 35" HEIGHT / AVAILABLE IN 27" HEIGHT!



PULL-OUT GRAB & GO SERIES

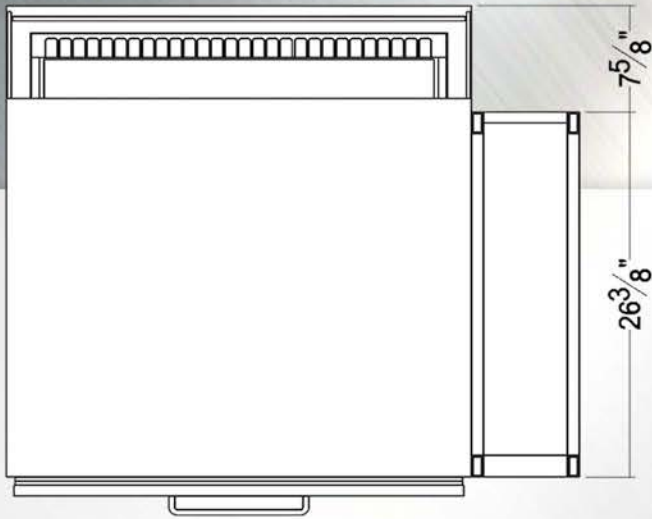

REMOTE-REFRIG.

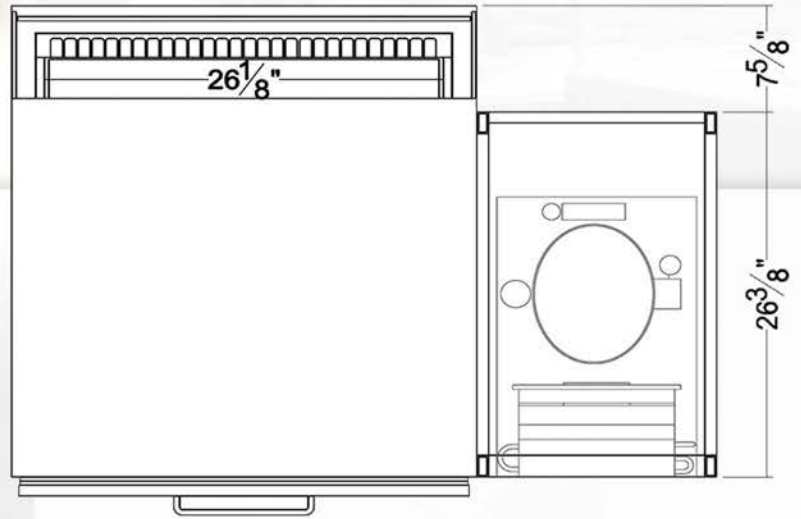
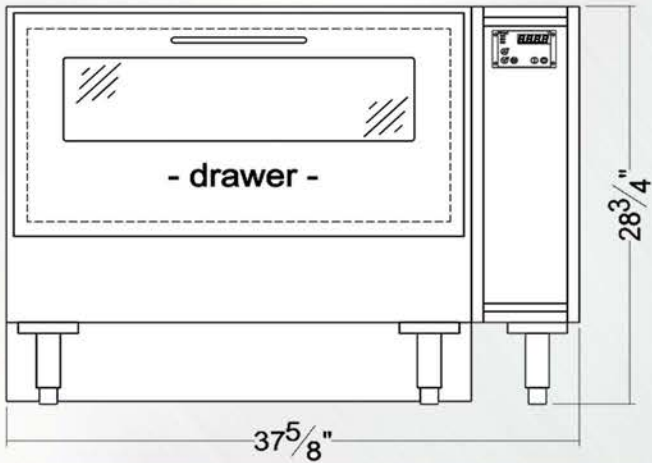

SELF-CONTAINED

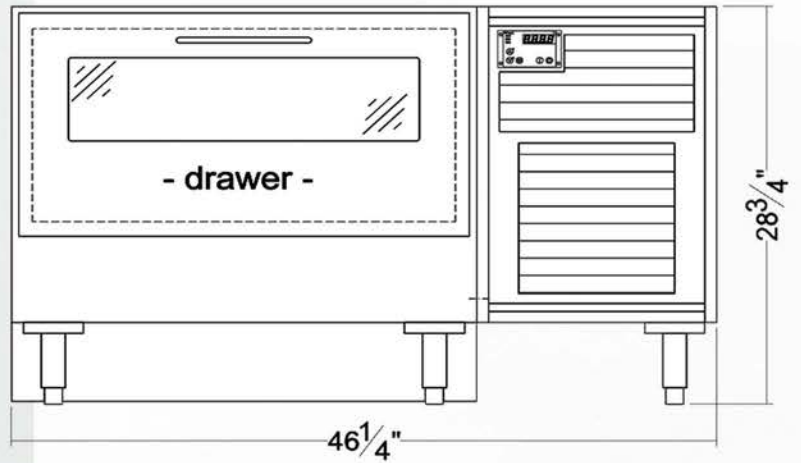

Counter Top

Vienna



The Vienna counter top displays offer your choice of **chilled** or **heated** applications. Units can be decoratively displayed built into a counter or die-wall, and are designed for the storage of beverages or pre-packaged goods!



CHILLED SERVICE



CHILLED GRAB & GO



HEATED SERVICE

Extended

D designs

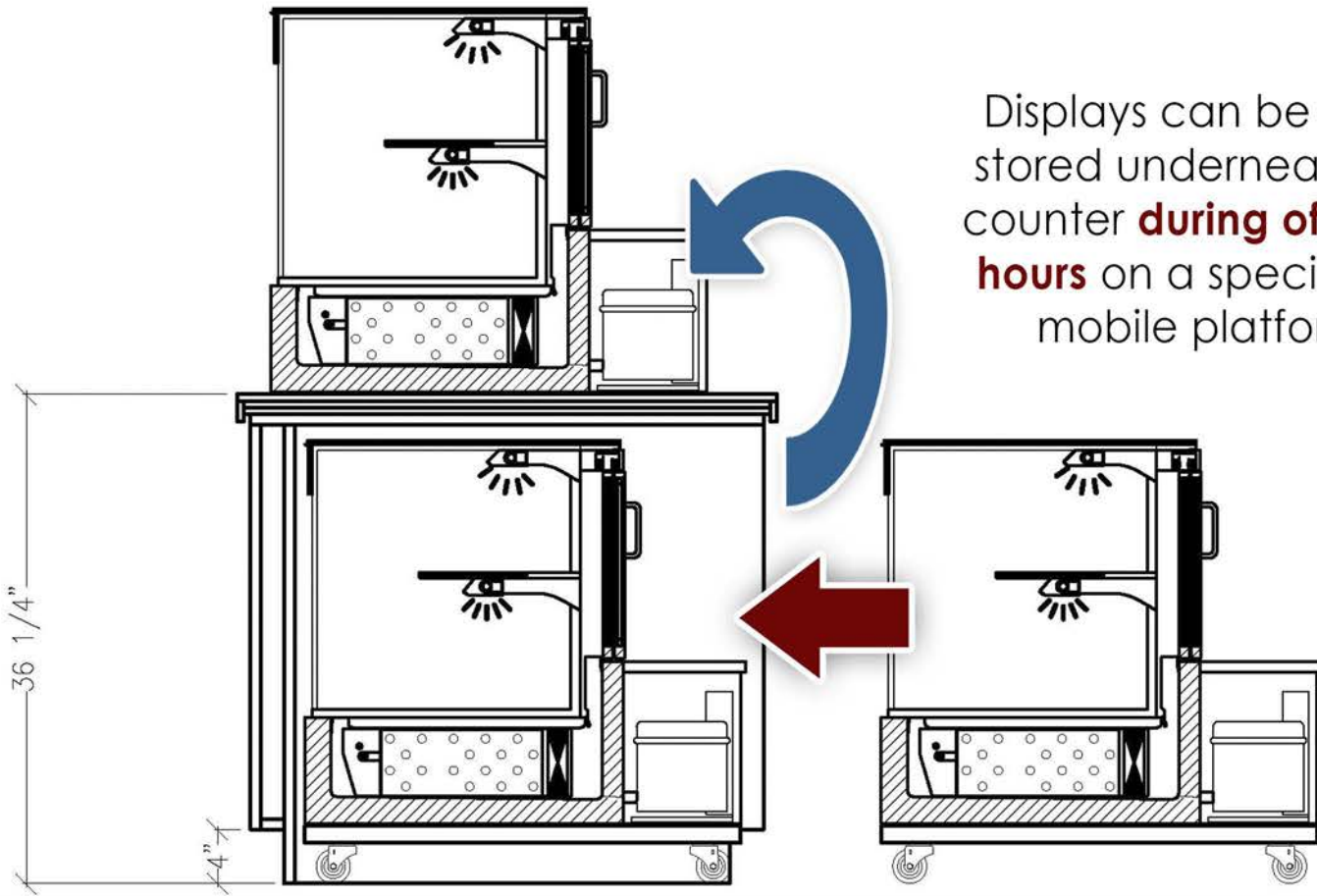

Displays can be easily stored underneath the counter **during off peak hours** on a specialized mobile platform.

UNDER COUNTER STORAGE



Vienna



A standard, with a **twist!** The Vienna air pan **switch** is pure drop-in style with option of a **"flip-of-the-switch"** to change the unit from refrigerated air over pan to a heated unit. Dual controls are easily mounted at the rear of the unit.

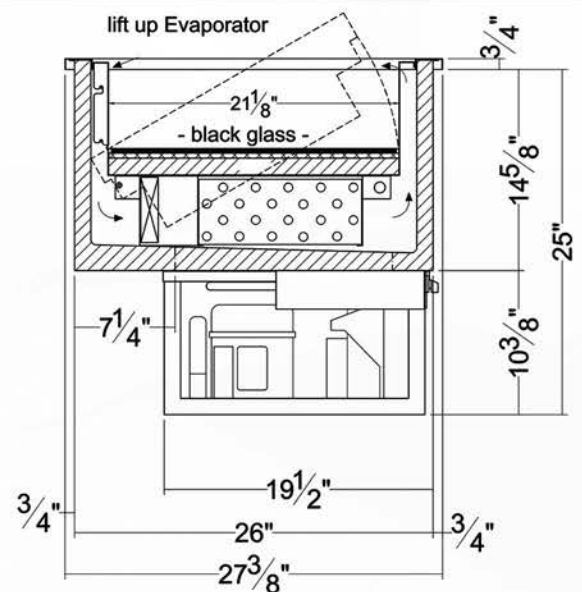
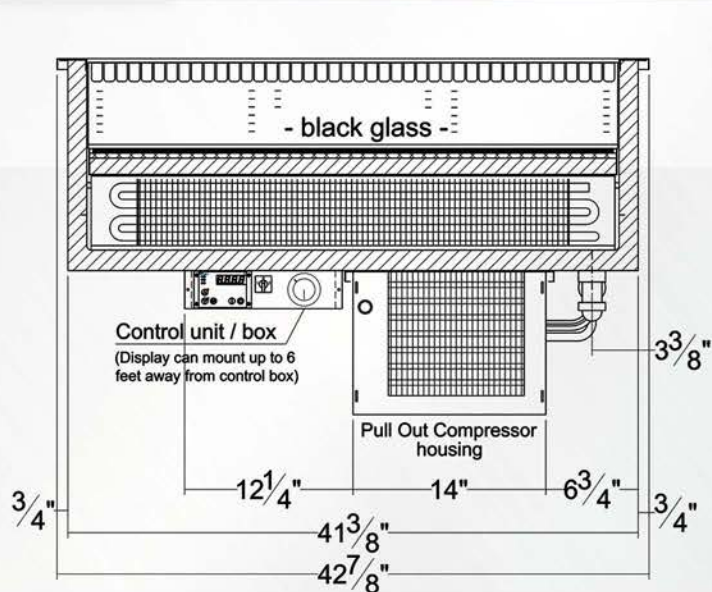

AVAILABLE SIZES: 2, 3, 4 PAN

! Heat operation will require heated sneeze guard
Consult factory for additional information

R e q u i r



INNOVATION, with INSPIRATION!

A refrigerated air over design integrated within the counter build so they look as one. This gives the ultimate in one piece design!

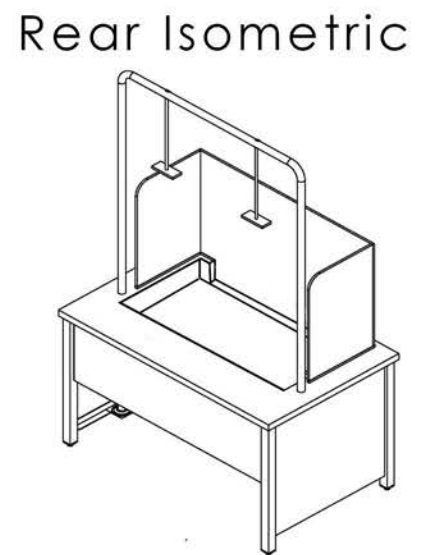
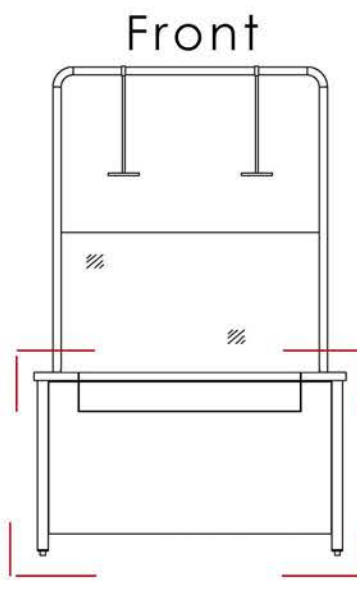
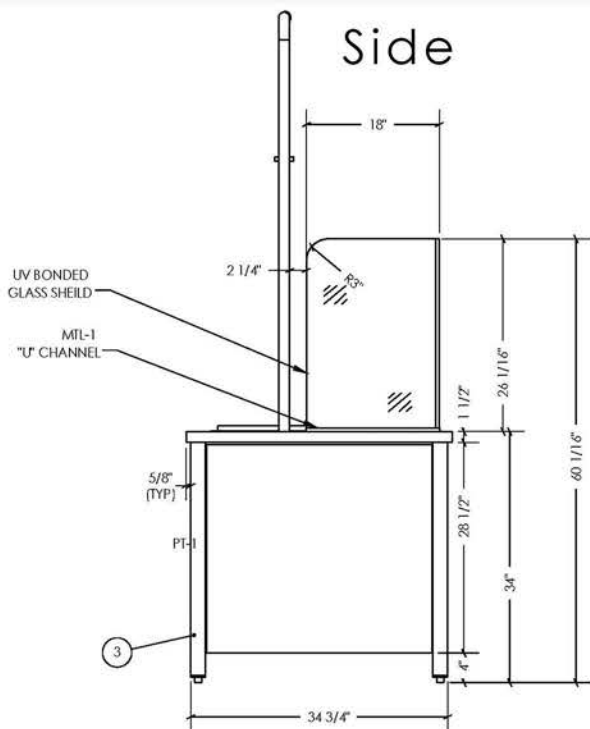

AVAILABLE SIZES: 4', 5', 6', 8'

BRAVO *SLANTED*



*PERFECT CHOICE FOR **PRE-PACKAGED GOODS!***

A new slant on the grab and go experience! The new Bravo Slant brings a new look to the self-select Service Market. This new grab and go case has a reclined vision to what was either totally vertical or totally horizontal refrigerated displays in the past. A two sided unit would make a great Island unit (remote compressor).

A single sided (self-contained) unit would work great as a front line case or up against a wall using RPI'S famous zero wall clearance!



AVAILABLE **SIZES: 4', 5', 6', 8', 10', 12'**

UNIQUE **BASE** CONSTRUCTION



ENCLOSED



OPEN

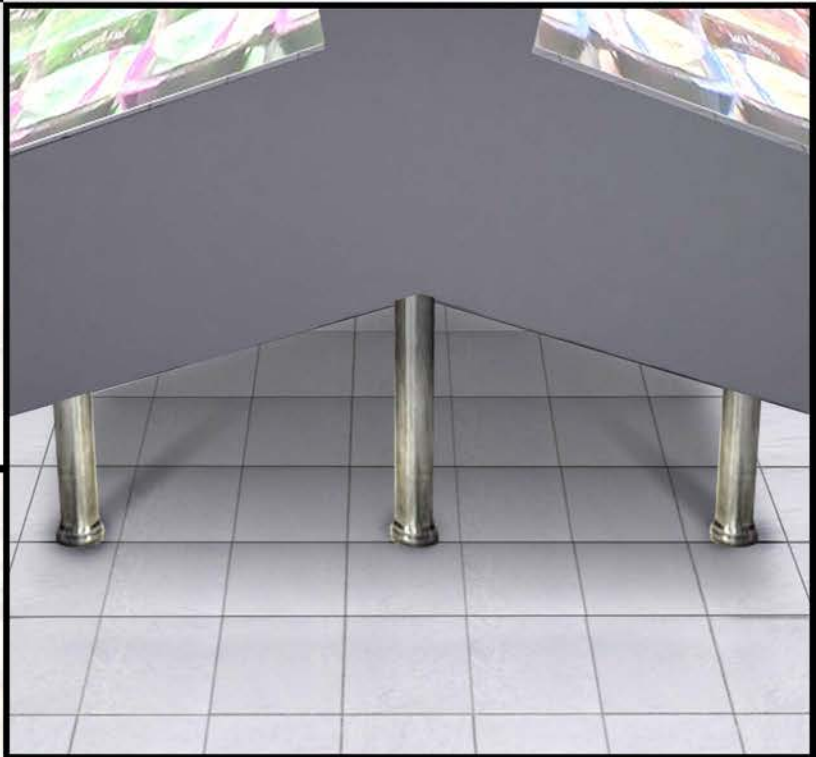

METAL FRAMED BASE CONSTRUCTION WITH BLACK PAINTED
EXTERIOR FINISH

MICRO MARKET SOLUTIONS!



A **COMPLETE MICRO MARKET** WITHIN 15 FEET THAT WILL MAKE A LARGE IMPACT ON GRAB AND GO PRODUCT SALES!

CRAFTED
CONVENIENCE

HUMMUS

BEVERAGES
SALADS

5

M



3



4



1A

- 1. AMBIENT DISPLAY:** STARTING ON LEFT WITH A 24" AMBIENT / NON REFRIGERATED DRY DISPLAY WITH ADJUSTABLE SHELVES AND L.E.D LIGHTS!
- 2. OLYMPUS II TURBO CHILL AIR SCREEN:** 60" TURBO CHILL SMART CONTROLLED WITH PATENTED TECHNOLOGY THAT HAS THE INTELLIGENCE TO DETECT IF FOOD PRODUCT REACHES 39.5 DEGREES. UNIT WILL SEND AN ALERT WHICH WILL THEN CLOSE THE MOTORIZED ROLL DOWN DOOR, ENGAGING IN TURBO MODE UNTIL PRODUCT REACHES 37.5 DEGREES WHICH WILL THEN RE-OPEN DOOR. THE NON-ATTENDED AIR SCREEN UNIT CAN NOW BE UTILIZED WITH CONFIDENCE!
- 3. FLEXESERVE OLYMPUS II:** 22" FLEXESERVE ZONE HEATED GRAB AND GO PATENTED UNIT HAS THE ABILITY TO CIRCULATE HEATED AIR, OFFERING LONGER SHELF LIFE AND PRESERVATION OF THE QUALITY OF THE PRODUCT. AVAILABLE IN 3 LENGTHS AND TWO HEIGHTS!
- 4. PORTE-CACHEE OLYMPUS II:** 48" PORTE-CACHEE-OLYMPUS AIR SCREEN WITH A PATENTED POCKET DOOR SYSTEM THAT IS IDEAL FOR USING THE UNIT AS A GLASS DOOR MERCHANDISER IF THERE ARE SLOW PERIODS OR ADVERSE AMBIENT CONDITIONS. THE DOORS OPEN AND "POCKET" WITHIN UNIT FOR OPTIMAL MERCHANDISING AS A GRAB AND GO REFRIGERATED AIR SCREEN!
- 1A. AMBIENT DISPLAY:** COMPLETING LINE-UP WITH A 24" AMBIENT DISPLAY!

5. TOP HEADER: CAN BE CHANGED TO **UNIQUE PERSONALIZED MESSAGE!**

RPI TURBO CHILL™ OLYMPUS II



OUR LATEST **INNOVATION!**

Our patent pending refrigeration system gives you turbo chilling ability, that offers you the assurance of proper food temperature!



AVAILABLE **SIZES: 5' ONLY**

HOW DOES IT WORK?



TURBO CHILL/DOOR CONTROLS



WITH INDICATOR LIGHT
ALERTS OPERATOR
WHEN **TURBO CYCLE**
HAS **COMPLETED**

MOTORIZED
ROLL-DOWN LOCKING
SECURITY DOOR,
OPENS WHEN **TURBO**
CYCLE IS COMPLETE!



REMOVABLE FRONT
AIR GRILL

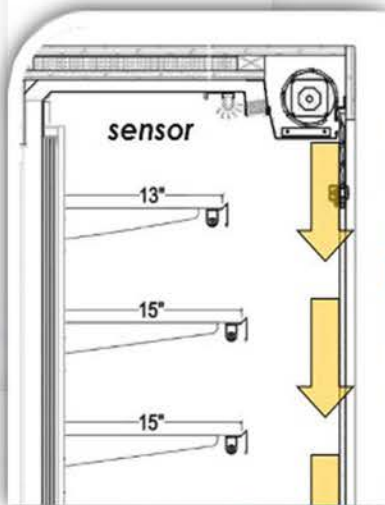

- The Turbo Chill function will only come on when the Hi-Temperature alarm activates. There is also a 3 minute hi-temp alarm delay

CONSULT FACTORY FOR **ADDITIONAL INFORMATION**

RPI PORTE CACHEE™ OLYMPUS II



INTEGRATED BEAUTY!

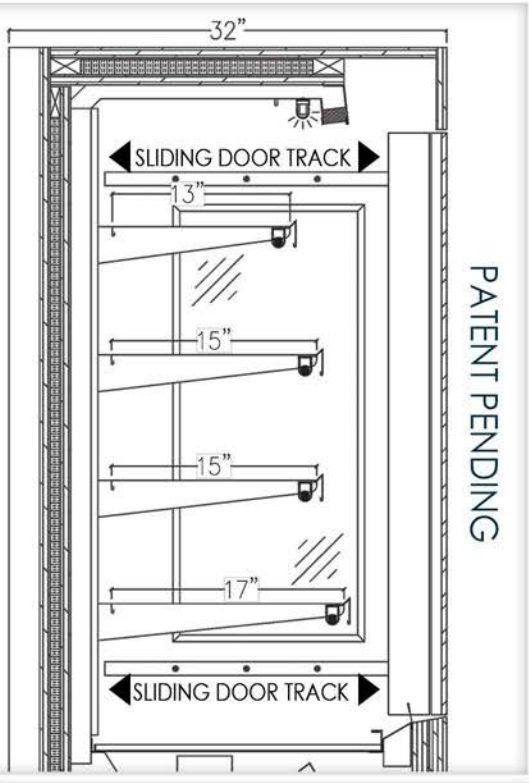

The Olympus Porte Cachee Air Screen is a standard air screen modified with a vertical integrated pocket door system that allows the unit to be closed during off peak or night hours. This is ideal for adverse ambient conditions which may cause a negative impact on refrigerated holding temperatures.



OPTIONAL ACRYLIC FINISHES

PORTE CACHEE AVAILABLE IN 4' UNITS ONLY

HOW DOES IT WORK?



DOORS IN
CLOSED
POSITION



PULL DOORS
OPEN



SLIDE DOORS
INTO **UNIT**



BEHIND THE DESIGN

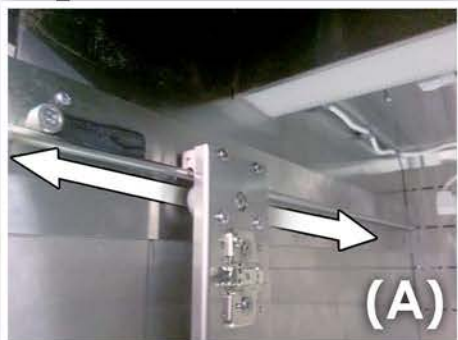

(A)



(B)



(C)



(D)

Doors attach to arm, that tracks along an interior rail system (A), top and bottom mounted hinges allow for opening/closing (B), this combined system allows for the pull-out doors, to 'Pocket-in' during peak hours (C & D)

THE RPI ADVANTAGE



Modular Method!

A modular standard in design allows the ability to offer a value engineered model, in either a full size, or half size unit that can be refrigerated for isolated compartments for wine, champagne, micro beers, cheese or smoked meats . Units can be stacked with endless choices for exterior finishes giving you the one of a kind look at a very smart valued price!



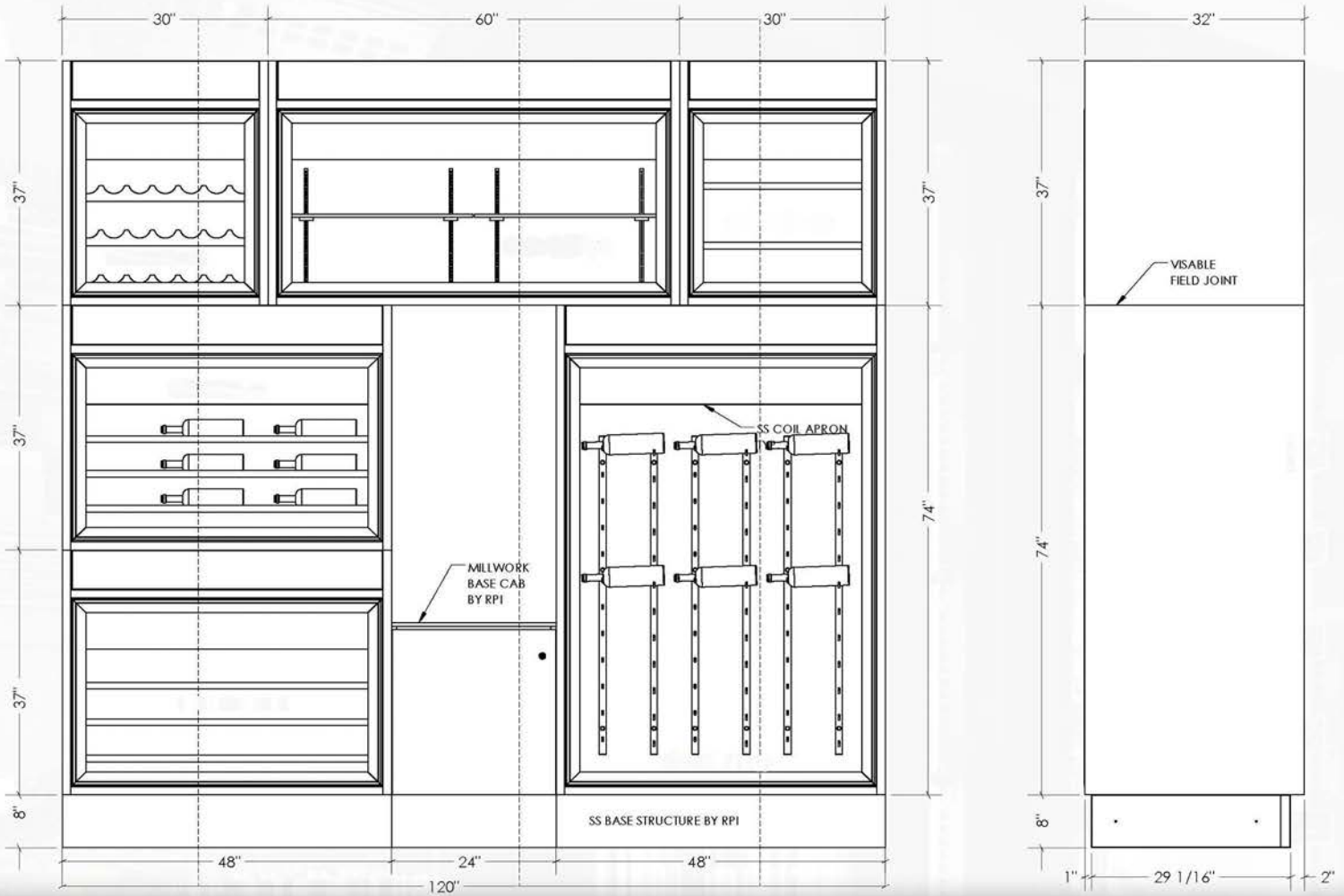

Meat, Cheese, Wine & Beer Display Modules!

**MIX & MATCH FOR THE
ULTIMATE DESIGN
OPPORTUNITY!**

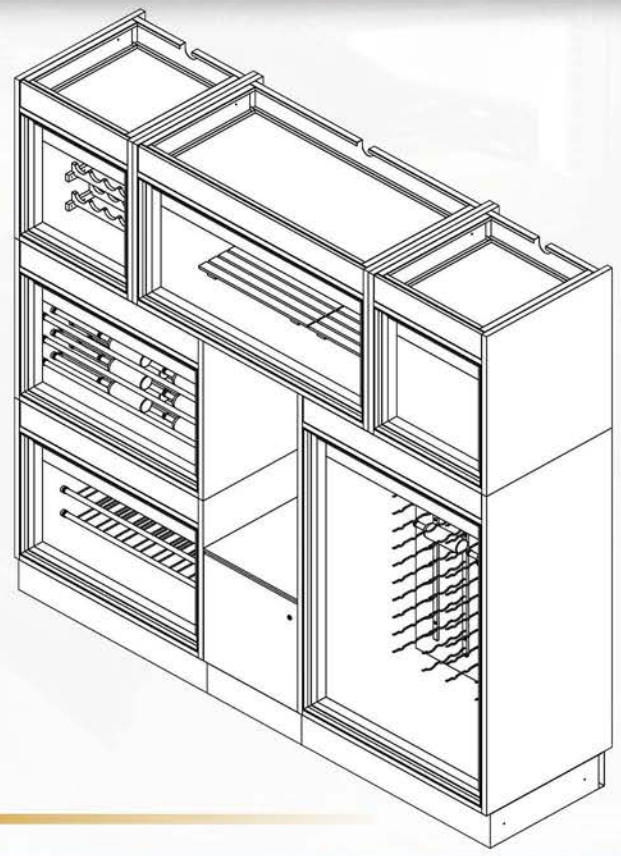



GENEVA II SERIES

The Geneva II series is the next level of continual display, and is offered in a wide variety of straight and curved modules. Units can be used to maintain the quality of prepared foods, deli, meat, cheeses and salads. Add the **FLEX SERIES** paneling for enhanced and enticing display opportunities!



LIFT-UP FRONT GLASS





RPI



RPI

© RPI Industries, Inc. All Rights Reserved.

RPI Industries, Inc. ● 220 Route 70, Medford NJ 0805 ● Phone: (609)714-2330 ● Fax: (609) 714-2331